



INSTALLATION MANUAL

MODEL FP-80
WITH LOW PRESSURE WARNING LIGHT

FOR 24 VALVE CUMMINS® POWERED
DODGE® TRUCKS

READ INSTRUCTIONS THOROUGHLY
BEFORE BEGINNING INSTALLATION.

EKSTAM FUEL PREPARATOR, INC.
5400 BUSINESS 50 WEST
SUITE 8
JEFFERSON CITY, MO 65109

(573) 635-0555 VOICE
(573) 635-0778 FAX

FUEL PREPORATOR®
AirDog™
MODEL FP-80

Welcome to the **FUEL PREPORATOR® AirDog™** Air/fuel Separation, filtration and delivery system for the diesel engine.

The installation of the **AirDog™** can be made relatively easy by following the steps outlined in this manual.

1. Inventory the package components completely. Notify *EKSTAM FUEL PREPORATOR, INC.* Immediately of any parts missing or damaged.
2. Read the owner's manual and the installation manual completely. Understand how the system operates and installation recommendations before beginning installation.
3. The installation recommendations contained herein are suggested installation guidelines only. Individual installations may vary.

Use good judgment and common sense when installing the AirDog™

If any installation procedure is uncertain, contact *EKSTAM FUEL PREPORATOR, INC* for technical assistance.

Please fill out and mail the Product Registration and Warranty Card enclosed with this manual.

TABLE OF CONTENTS

Section 1 AirDog™ OVERVIEW

Section 2 Parts List

Section 3 Safety Guidelines and Warnings

Section 4 Installation of Mounting Brackets,
& AirDog™

Section 5 Installation of Fuel Lines

Section 6 Installation of Electrical Harness

Section 7 Final Check List



OVERVIEW

The FUEL PREPORATOR® AirDog™ Air/Fuel Separation System is the “missing link” between the fuel tank and the engine for diesel powered equipment.

The AirDog™ delivers clean fuel to the engine free of virtually all air/vapor and at a positive flow. Thus, allowing the engine “test cell” performance and efficiency, while in “real world” use.



The AirDog™ FP-80 is suitable for all stock and slightly modified 5.9 Cummin's® Diesels. Connecting the AirDog™ to the stock 3 /8" OD (outside diameter) fuel suction tube at the tank is OK.

Satisfactory performance and operation from the AirDog™ depends upon proper installation and maintenance.

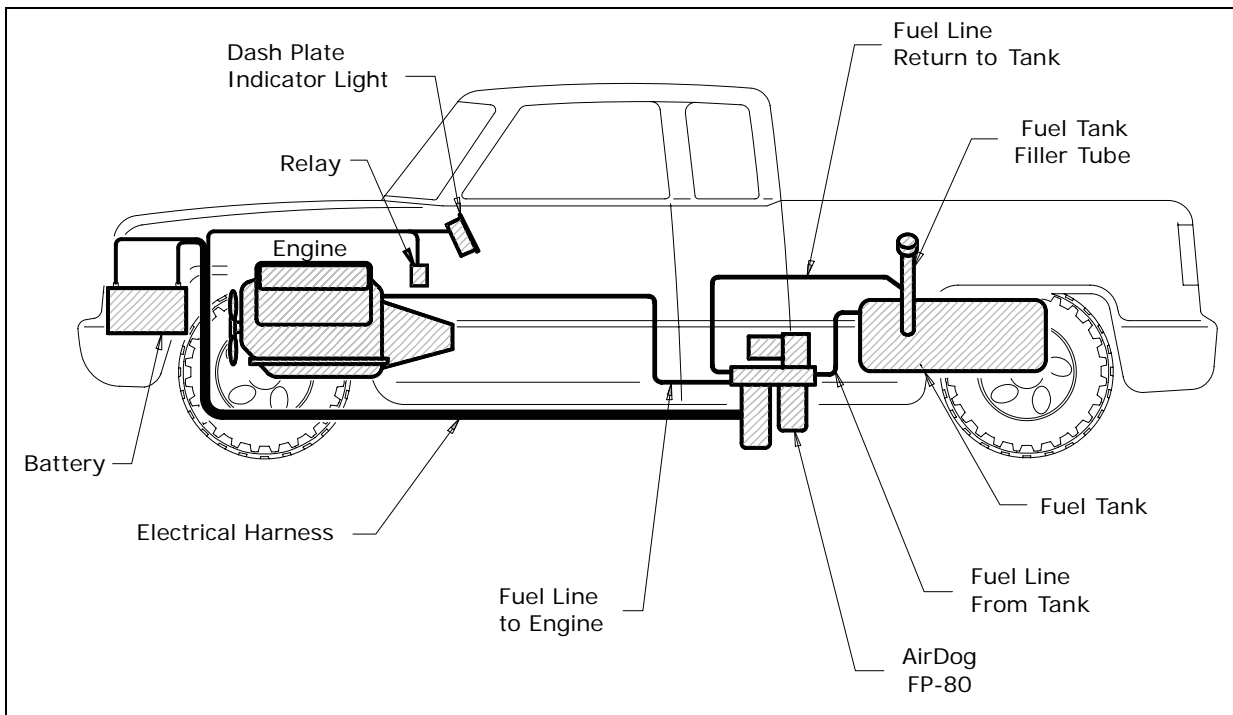
TYPICAL INSTALLATION

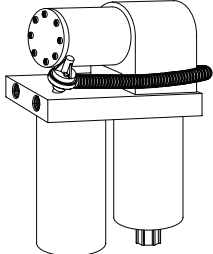
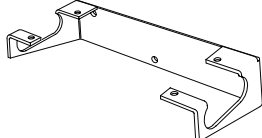
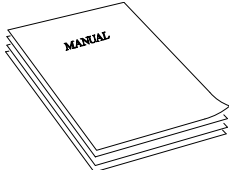

AirDog™ PARTS LIST

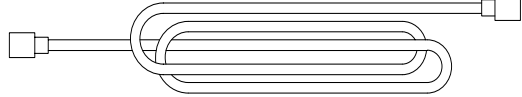
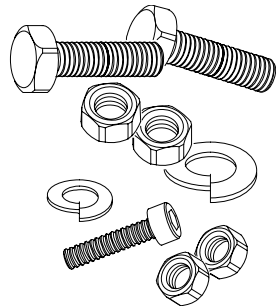
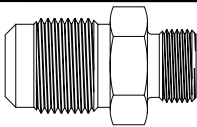
Qty	Description	Part Number	Image
1	AirDog™	001103-01	
1	Mounting Bracket	001062-01	
1	Installation Manual	001103-01-05	
1	Indicator Light Assembly Includes: Indicator Light, Dash Plate & Grommet	001004-01	
1	Electrical Harness	001105-01	
1	Mounting Hdwr Kit, Unit-to-Bracket Includes: 4 II-A20C Socket Head Cap Screws, 1/4-20 x 1-1/4" Lg. Stainless Steel 3 1J-1-C20SN Bolt, Hex Hd., Grade 8, 3/8-16 x 1-1/4" Lg. 4 1S-1-ASN Hex Nut, 1/4-20, Stainless Steel 3 1S-1-CSN Hex Nut 3/8-16 Steel, Nickel Plated 4 1R-6-ASN Washer, Split-Lock, Helical, #1/4, Stainless Steel 3 1R-6-CSN Washer, Split-Lock, Helical, #3/8, Steel, Nickel Plated	001067-01	
2	Fuel Fitting, #8 SAE male to 3/8" -NPT	4A-1-01-D-C-S	

NOTE: Various components and materials discussed in this manual that are marked "(*)" are special to a particular vehicle installation and supplied in a separate kit.

SAFETY GUIDELINES AND WARNINGS!

IMPORTANT Use diesel fuel compatible thread sealer on all NPT tapered pipe thread fuel fitting connections!

IMPORTANT When installing push lock fuel line fittings remember to lubricate the fittings with oil before inserting fittings into the fuel line.

NOTE: Proper location of the AirDog™ on the vehicle is essential. Consider hazards presented to the equipment by road debris and the elements.

WARNING! Frame rails should not be drilled into or welded upon.

CAUTION: Wear safety glasses when operating power tools such as drills and grinders or when using a punch or chisel.

CAUTION: Use common sense when routing fuel lines and electrical harnesses. Keep them away from hot exhaust components and/or moving parts. Properly secure lines to prevent chaffing.

DODGE/CUMMIN'S 24 VALVE INSTALLATION PROCEDURES

Installation of AirDog™ and Bracket to the Truck's Frame

Loose assemble mounting bracket to frame with backing plate using 3/8" x 4 1/2" bolts, lock washers, and nuts included in the kit. Position mounting bracket so that its back is adjacent to the rear of the transmission tail shaft (above the transfer case skid plate on 4 x 4's) to allow ease in changing of the fuel filter. After positioning bracket, properly torque fasteners.

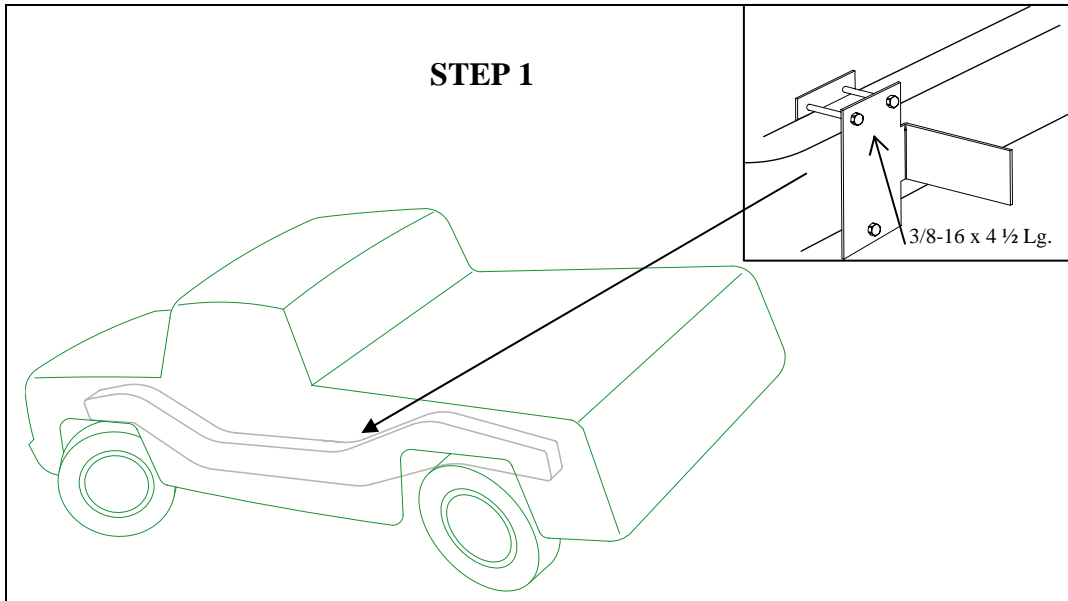
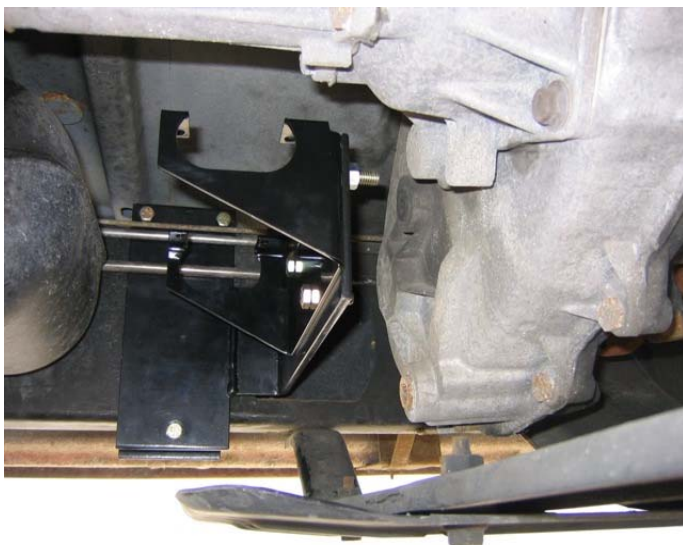
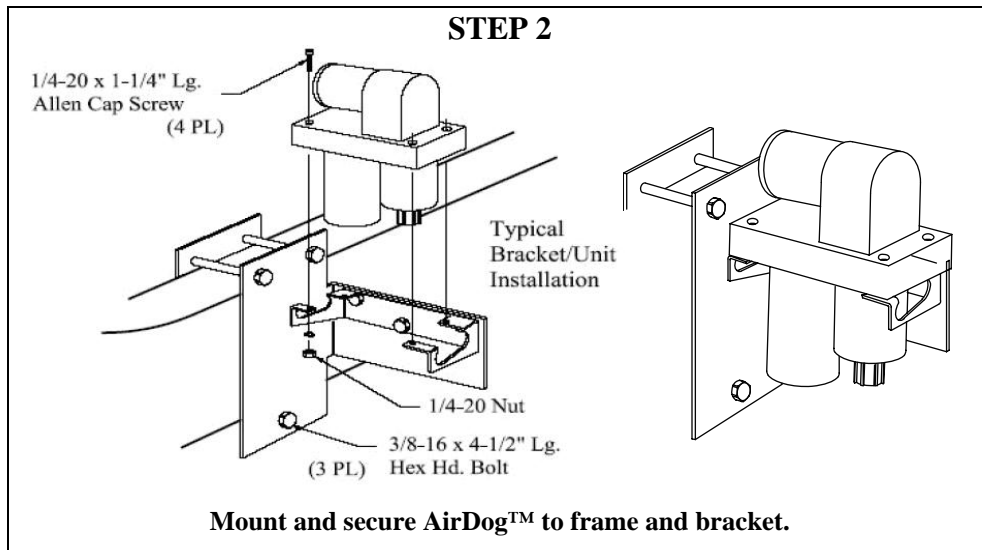

Figure 1: Image taken on a Dodge 2500 (stock model)

Install the two 3/8" NPT x #8 SAE flare fuel fittings into the AirDog™ ports marked "FUEL IN" & "ENGINE". Use diesel compatible thread sealer when installing these fittings.
Note: Return fuel fitting comes factory installed to hold pressure regulator in place.

Remove fuel filter and water separator from AirDog™. Adjust AirDog™ to its bracket using 1/4-20 stainless steel socket head screws provided. Attach AirDog™ and bracket to the **frame mounting bracket** with 3/8-16 Hex head bolts. Secure the entire units, as illustrated.



This is how your AirDog should look like after these procedures have been completed.

FUEL LINES

THIS SECTION IS APPLICABLE TO STOCK AND SLIGHTLY MODIFIED ENGINES.

Fuel Suction Line

- 5 - 1 From end of fuel line supplied with attached 'Quick Disconnect' fitting, measure and cut length of line required to connect fuel tank SUCTION port to AirDog™ inlet port marked "Fuel In".
- 5 - 2 Install #8 female swivel x 1/2" 'push lock' fitting into other end of fuel line (Ref. 5-1).

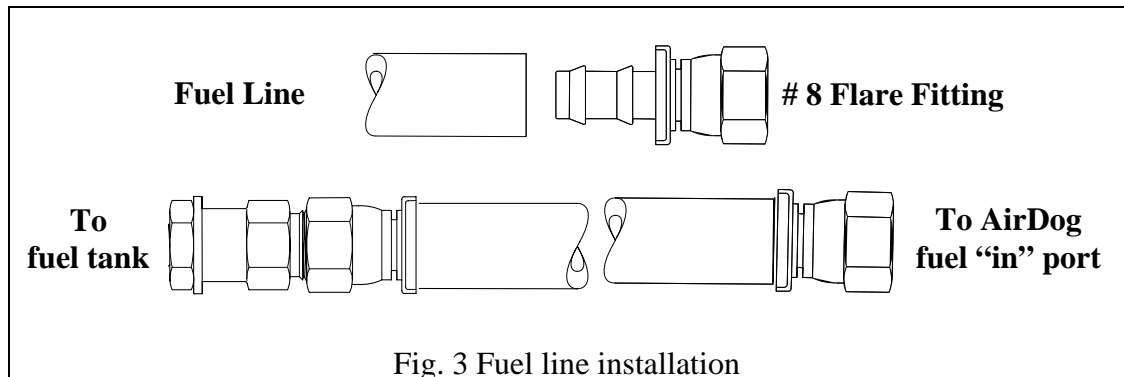

- 5 - 3 Remove the original fuel suction line from fuel tank by squeezing the tabs on the end of the connector together. Consult factory manual if unsure. Connect the 'New Fuel Line' Quick Connect fitting to fuel tank by pushing the connector onto the tank supply tube until connector seats. Check connection for seating.

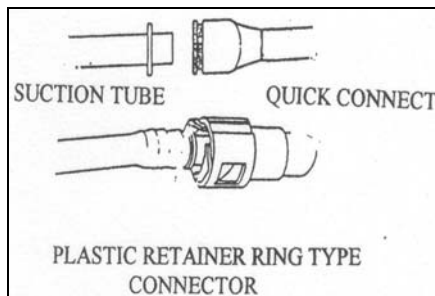
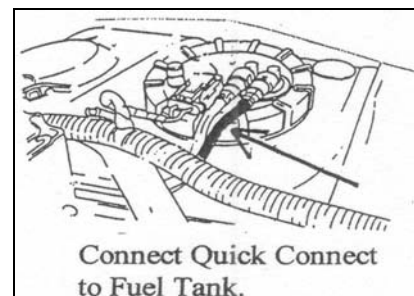

Fig. 4



Fuel Suction Line
Cont'd

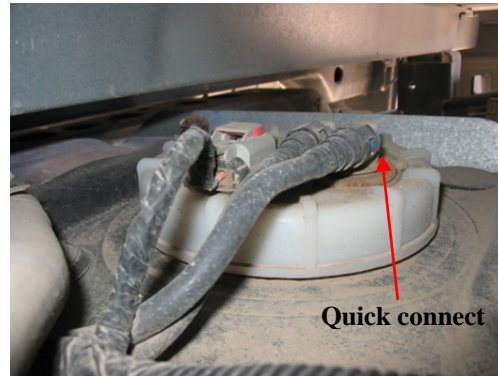

Figure 5: Fuel tank

To release quick-connect fitting from fuel tank suction tube, firmly push fitting toward the component being serviced while firmly holding the plastic retainer ring into the fitting. While the plastic ring is depressed, pull the fitting assembly from the suction tube. Use care to press the retainer ring squarely into the fitting body. It may be difficult to disconnect the fitting if the retainer is cocked during removal.

Note: After removing the factory line check to make sure that the blue plastic retainer was removed with the line. If the blue retainer remained attached to the tank tube, it **MUST** be removed before the AirDog™ fuel line will connect to the tank tube.

- 5 - 4 Connect 'New Fuel Suction Line' swivel end to #8 male flare fitting at AirDog™ port marked 'FUEL IN'.

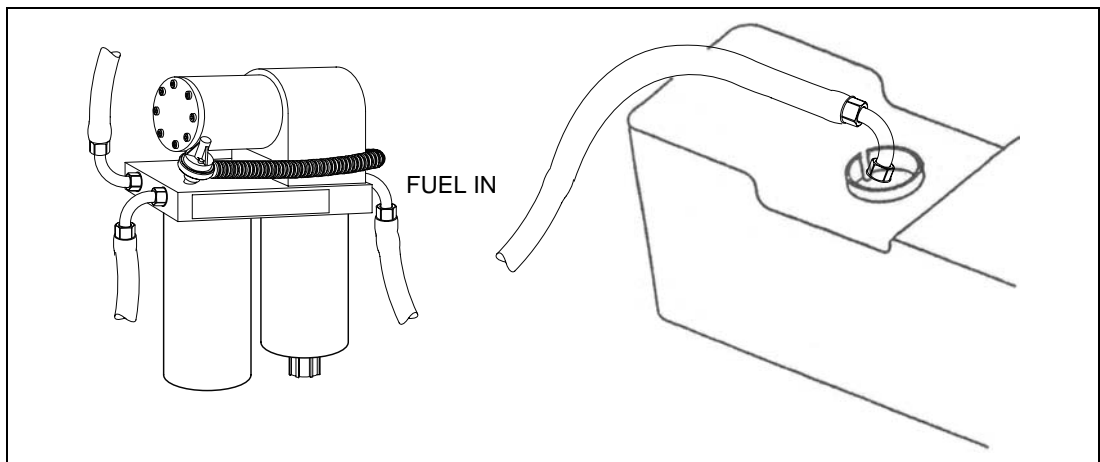
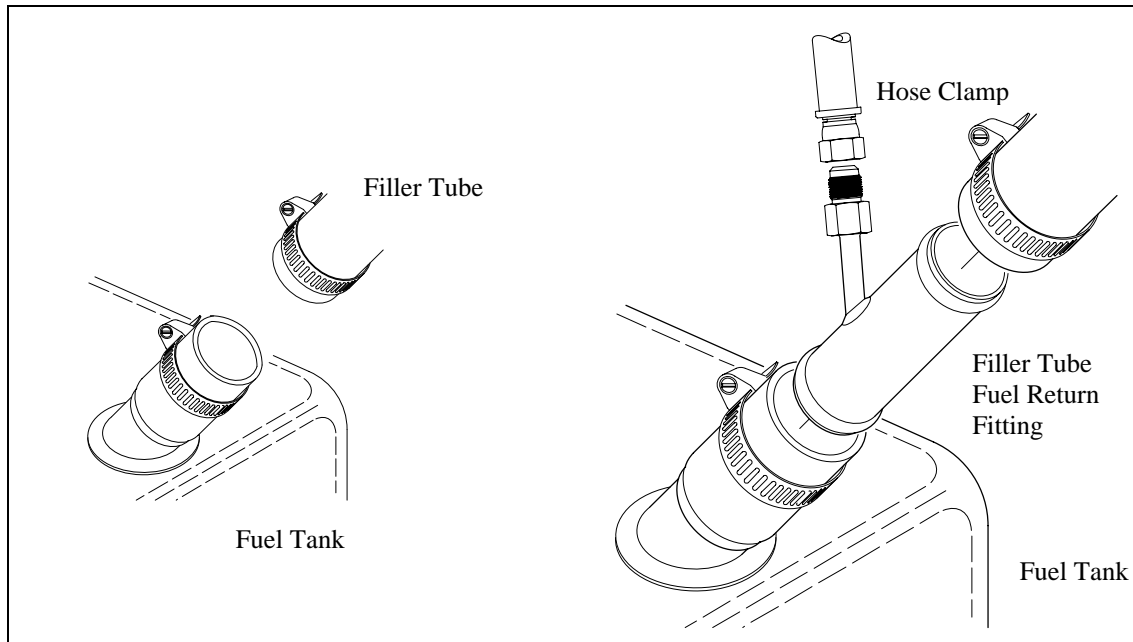

Figure 6: Connecting the AirDog™ to the suction line of the tank

Fuel Supply Line

'RETURN TO TANK' FUEL LINE

5 - 5 Installing fuel 'Return To Tank' assembly in filler tube.



STEP 1.

Cut filler tube as illustrated, removing 1½ inches. Loosen assembly clamps on each end of filler tube.

STEP 2.

Insert 'Return To Tank' assembly in filler tube, rotate and position #8 flare fitting. Properly tighten clamps.

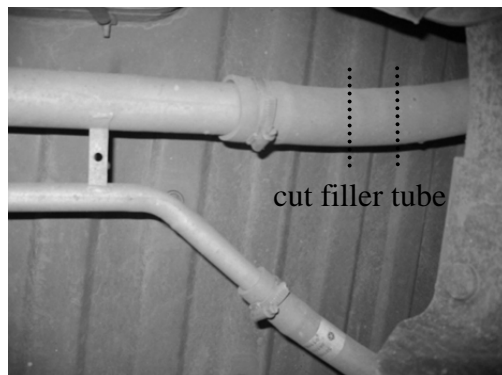
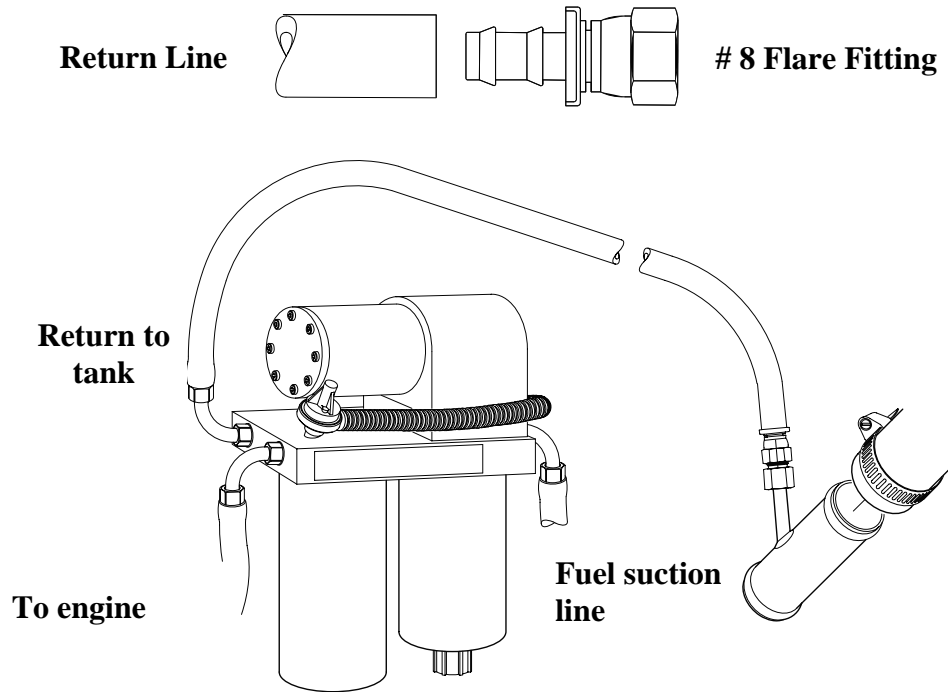

Figure 7: Installing 'Return To Tank' assembly

Fuel Supply Line

5 - 6 Installing fuel return line.



Measure and cut length of 1/2" ID fuel line necessary to connect AirDog™ to 'Return To Tank' assembly in filler tube. Install #8 Swivel x 1/2 " pushlock fitting into each end of fuel line.

Connect fuel line to AirDog™ port marked 'TANK' & #8 flare fitting on 'Return To Tank' filler tube assembly. Properly torque fittings.

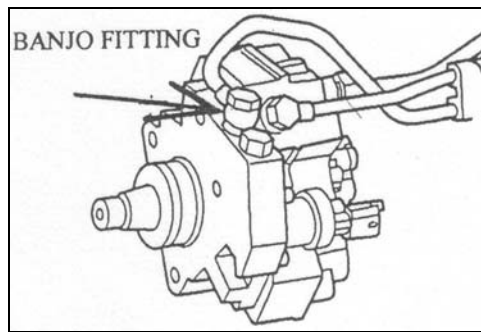

Figure 8: Connect return fuel line here

Fuel Supply Line From AirDog™ To Engine

The *AirDog™* fuel filter is made of the same Stratapore™ media as the OE filter. For optimum engine performance, it is recommended to by pass the factory filter head when installing the *AirDog™* fuel system.

- 5 - 7 Remove original factory fuel supply line at the engine by removing the banjo fitting from fuel inlet port in VP44 injector pump or inlet port on Common Rail engine. Install the 12mm x #8 flare fitting supplied with *AirDog™* accessory kit into the engine port vacated by the original banjo fitting. Properly torque #8 flare fitting.



COMMON RAIL ENGINE – CP3

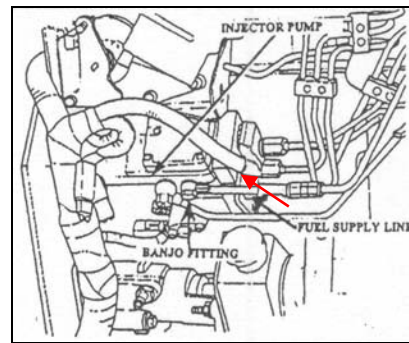

VP-44

2003-2004 models

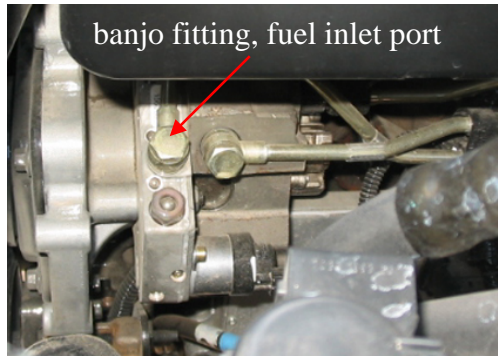

1998½ -2002 models

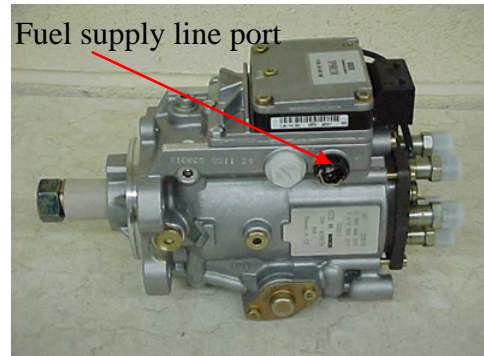

Figure 10: Fuel supply line

5 - 8 Measure and cut length of line required to connect the 'Fuel to Engine' port on AirDog™ to 12mm x #8 flare (Ref. 5-7) on engine fuel inlet port.

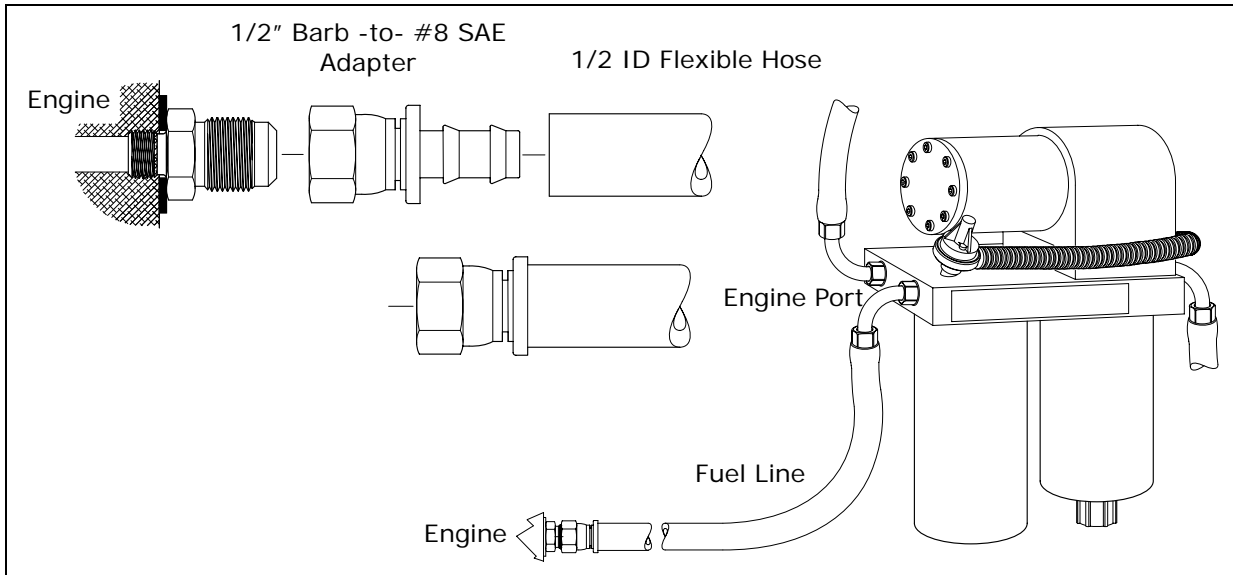

Figure 11: Connecting AirDog™ to engine

Install 90° x 1/2" hose barb on end to engine. Install straight hose barb on end to AirDog™. Connect 90° fitting to 12mm x #8 flare on engine. Properly route and connect fuel line to AirDog™ fuel port marked 'ENGINE'.

IMPORTANT: Properly torque all fuel fittings and connections. Use 'ties' to secure fuel lines to vehicle to prevent chaffing and abrasion

WIRING HARNESS



The *AirDog™* is equipped with a relay controlled wiring harness that connects directly to the battery and is activated by the OE fuel pump connection. It is additionally equipped with a "low fuel pressure" warning light.

- 6 - 1 Connect the RED lead to the POSITIVE (+) post of the driver's side battery. Connect the GREEN lead to the NEGATIVE (-) post of the same battery.
- 6 - 2 Route the wiring harness to the *AirDog™* and connect the 3 pin Deutsch connector to the corresponding connector on the *AirDog™*.
- 6 - 3 Secure the relay to the vehicle at either the engine side wheel house or firewall near the steering column.
- 6 - 4 Disconnect the OE fuel pump lead from the ECM connection (Deutsch, two pin connector).
- 6 - 5 Connect the *AirDog™* 'Relay activation lead' to the OE fuel pump ECM connection.
- 6 - 6 Drill a 5/8" hole in firewall approximately 2 inches to the door side of the steering column to allow entry of the Indicator Light harness into the passenger compartment.
- 6 - 7 Route the Indicator Light harness through the firewall. Install the grommet supplied in kit around wiring harness where it passes through the firewall to prevent chaffing.
- 6 - 8 Install Indicator Light and Dash Plate in lower left dash area or where desired. Drill a 11/16" hole at the desired location to mount the indicator light assembly. Install the adhesive backed dash plate by removing the backing and matching the corresponding dash plate hole with the 11/16" hole.
- 6 - 9 Properly assemble the indicator light in the dash plate. Connect the two female connectors on the wiring harness to the spade connectors on the indicator light.

BE SURE TO PROPERLY ROUTE AND SECURE THE WIRING HARNESS TO THE VEHICLE.

INITIAL START PROCEDURE

The *AirDog™* is a self priming system, however, to prevent damage to a dry seal and reducing the life expectancy of the system, it is recommended to prefill the water separator with diesel fuel before initial startup.

- 7-1 Prefill the water separator with diesel fuel.
- 7-2 Turn the starter key to the on/run position.
Note: It may be necessary to momentarily engage the starter in order for the ECM to energize the *AirDog™*.
- 7-3 While the *AirDog™* is on, bleed the fuel line to the engine by loosening the fuel line connection at the engine fitting. As soon as the line is purged of air and pure fuel is observed, properly tighten the fuel fitting. NOTE: put a rag or shop towel over and around fitting to prevent splatter. Catch all spilled fuel and dispose of properly.

RECHECK ALL FUEL FITTINGS FOR LEAKAGE AND PROPERLY TORQUE. BE SURE ALL LINES ARE PROPERLY ROUTED TO PROTECT FROM EXCESSIVE HEAT AND SECURED TO PROTECT FROM CHAFFING AND ABRASION. RECHECK ALL ELECTRICAL LINES, SECURE AS NECESSARY.

- 7-4 Start engine!

NOTE: Should any installation problems arise, please call, toll free 1-877-463-4373, for assistance (Monday – Friday, 8:00 am – 5:00 pm CST).

Visit our website at www.airdog.com for updated materials and frequently asked questions.